

rc_viscore - High-Resolution 3D Stereo Sensor

Technical Specifications

The rc_viscore is a high-resolution IP54-protected 3D stereo sensor with an integrated rc_randomdot pattern projector. It provides 12MP camera images and – in combination with an rc_cube or the off-board SGM®Producer – depth, confidence and error images. The integrated rc_randomdot projector allows for dense depth images even in weakly textured scenes and the high resolution permits the detection of small parts with high accuracy. The rc_viscore can be used with any rc_reason module and is fully GenICam compatible.

Model (Type)	rc_viscore (210m-16-12M-H1-R)		
Baseline	210 mm		
Calibration	Factory-calibrated		
Mono/color	Monochrome		
Shutter	Global		
Pattern projection	Via integrated rc_randomdot projector		
Field of view	Horizontal	47°	
	Vertical	35°	
Wavelength	Visible		
Image resolution	4112 x 3008 pixels		
Framerate	9 Hz		
Focal length	16 mm		
Depth image resolution & FPS	4112 x 3008 pixel (Full) @ 2.8 Hz (Nvidia RTX2070) 2056 x 1504 pixel (High) @ 4.6 Hz (Nvidia RTX2070) 1028 x 752 pixel (Medium) @ 9 Hz (Nvidia RTX2070) 686 x 502 pixel (Low) @ 9 Hz (Nvidia RTX2070)		
Depth range (recommended)	Examples of possible depth ranges of the rc_viscore with 3.4 GB of GPU memory (rc_cube): Full depth quality: 0.89 - 1.00 m, 1.60 - 2.00 m, 2.18 - 3.00 m, 2.65 - 4.00 m High depth quality: 0.52 - 1.00 m, 0.66 - 2.00 m, 0.75 - 3.00 m, 0.80 - 4.00 m, 1.00 m to infinity Medium and low depth quality: 0.52 m to infinity		
Workspace	670 mm x 640 mm @ 1000 mm distance 1550 mm x 1280 mm @ 2000 mm distance 2430 mm x 1920 mm @ 3000 mm distance 3310 mm x 2560 mm @ 4000 mm distance		
Depth resolution	1000 mm 0.1mm 2000 mm 0.5 mm 3000 mm 1.2 mm 4000 mm 2.0 mm	Average depth accuracy	1000 mm 0.5 mm 2000 mm 2.0 mm 3000 mm 4.6 mm 4000 mm 8.2 mm
Interface & Applications	GenICam (via SGM®Producer software library GenTL) C++ API, ROS 1 & ROS 2 drivers available on GitHub Compatible with Halcon library		





roboception

Connectors	M12, 8 Pin, A-coded (power, GPIO) and 2x X-coded (GigE-network)
Dimensions	262 mm x 204 mm x 82 mm (W x L x H)
Weight	1.64 kg
Supply voltage	24 V
Max power consumption	48 W
Storage/transport temperature	-20° C to 60° C
Operating temperature	0° C to 45° C
Relative humidity (non-condensing)	20 % to 80 %
Warm-up time	No warm-up time required after power-up
Cooling	Passive
Approvals	CE, IP 54, ROHS

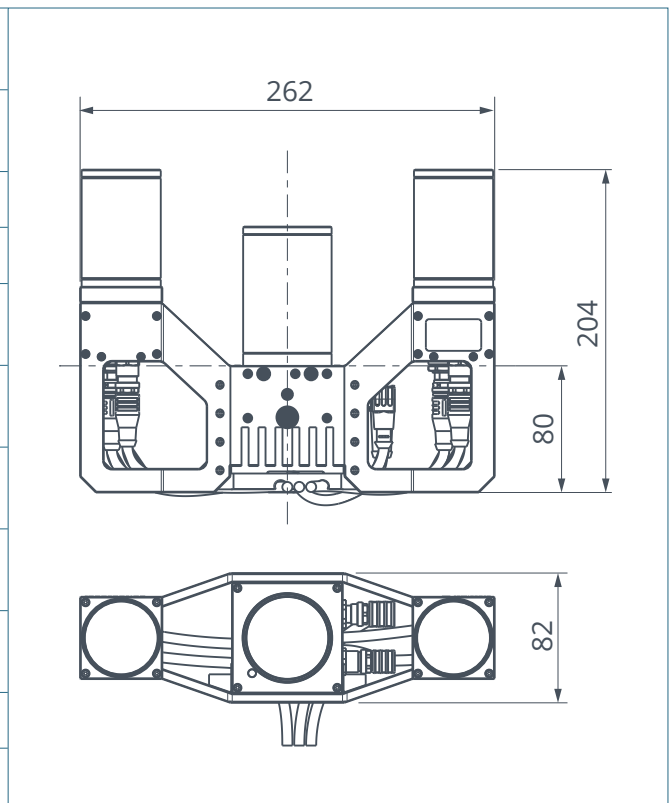

The scope of delivery of an rc_viscore includes a large CalibrationGrid, two 10 m Gigabit ethernet network cables and a 10 m power cable with an M12 connector and one open end, as well as the SGM®Producer software library (download), which is required for operating the rc_viscore with a computing resource other than the rc_cube.

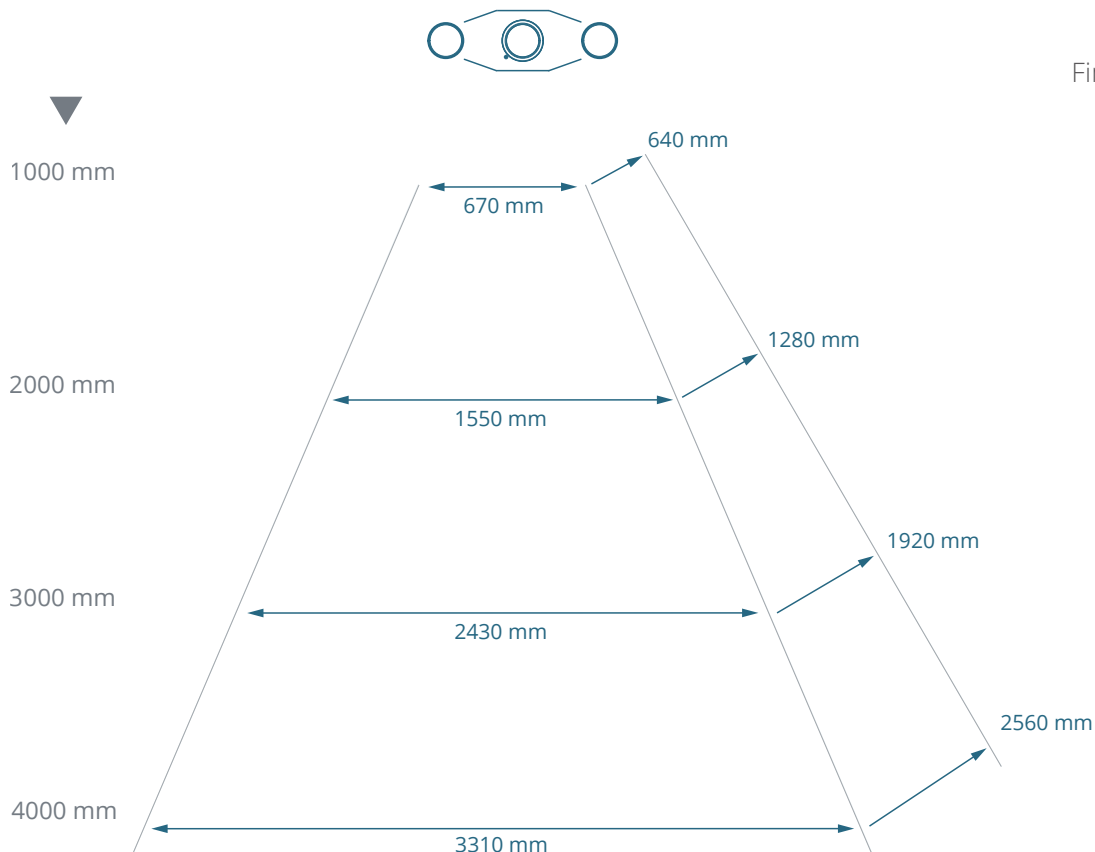

Find more information on doc.rc-viscore.com

Inquiries via sales@roboception.de



Roboception GmbH
 Kaflerstrasse 2
 81241 Munich
 Germany

www.roboception.com
 + 49 (0) 89 889 50 79 - 0